

CF1 Series ProVector® Explosion-Proof Heaters

The Ruffneck™ CF1 Series ProVector® explosion-proof convection heater offers the most reliable, dependable and trouble-free service available for heating hazardous locations such as those in the oil and gas well industry.

Features

- Sloped-top cabinet
- No exposed copper or brass
- High-velocity airflow
- 14-gauge steel cabinet, available with stainless steel construction
- One of the shortest cabinet lengths available
- Optional built-in thermostat
- Incoloy® 840 heating elements
- Radial-embossed aluminum plate fins
- Galvanized steel mounting brackets
- Approvals for Groups IIA, IIB & IIC

Benefits

- Prevents objects from being set on top which restricts airflow
- Corrosion resistant, suitable for H₂S environments
- Heats up area faster with better heat distribution
- Rugged reliability and unsurpassed corrosion resistance available with stainless steel construction
- Smaller profile utilizes less wall and floor space
- Reduced field installation costs
- Longer life expectancy
- Reduced fin warping for better heat transfer capabilities
- Quick installation
- Industry first approvals for built-in thermostat with IIA, IIB, IIC ratings



Physical Dimensions

CF1 ProVector® Physical Dimensions with x-Max® Housing

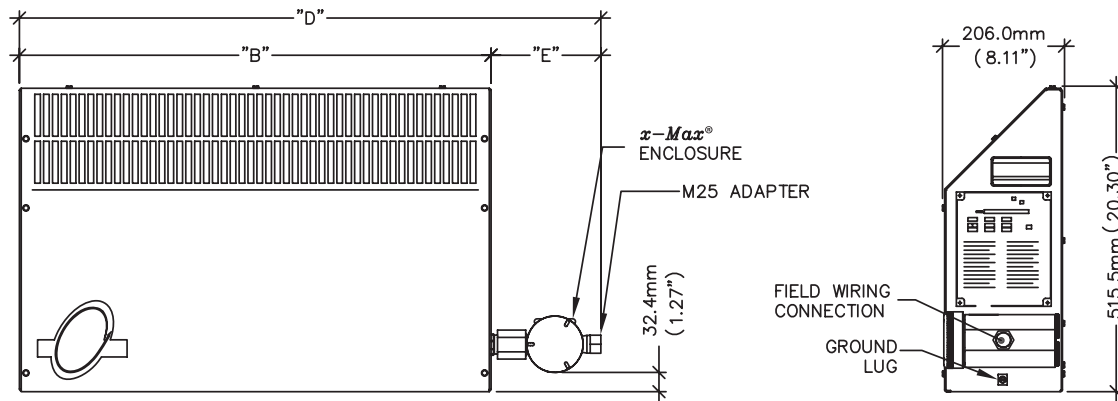

Heater kW Rating	'D' Dimension		'B' Dimension	'E' Dimension	
	w/o Extension	w/ Extension		w/o Extension	w/ Extension
0.75 to 3.00 (220 V) & 3.30 (T2) to 3.60 (T2)	984 mm (38.7")	1037 mm (40.8")	796 mm (31.34")	188 mm (7.4")	241 mm (9.5")
3.00 to 4.40 & 4.80 (240 V)	1444 mm (56.9")	1497 mm (58.9")	1256.0 mm (49.45")		
4.80 (380 V) to 7.60	1699 mm (66.9")	1752 mm (69.0")	1511.0 mm (59.49")		

CF1 ProVector® Physical Dimensions with Defender® Housing

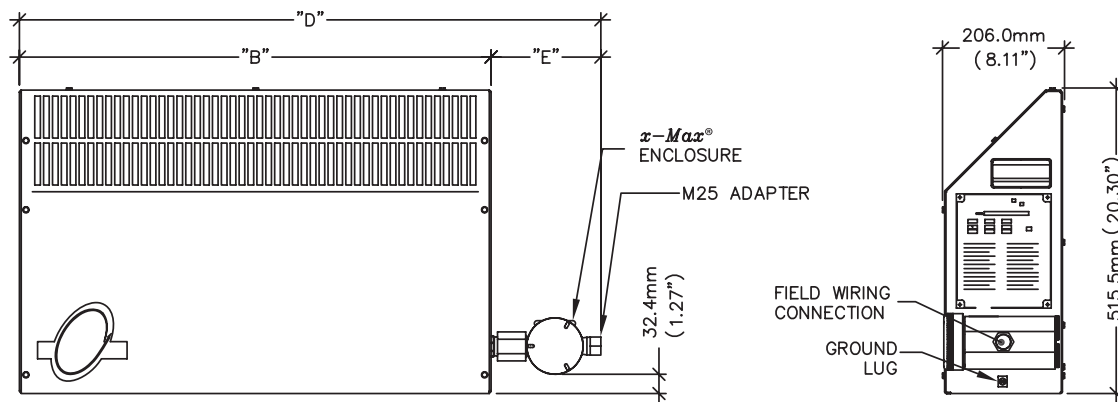

Heater kW Rating	'D' Dimension		'B' Dimension	'E' Dimension	
	w/o Extension	w/ Extension		w/o Extension	w/ Extension
0.75 to 3.00 (220 V) & 3.30 (T2) to 3.60 (T2)	973 mm (38.3")	1026 mm (40.4")	796 mm (31.34")	177 mm (7.0")	230 mm (9.1")
3.00 to 4.40 & 4.80 (240 V)	1433 mm (56.4")	1486 mm (58.5")	1256.0 mm (49.45")		
4.80 (380 V) to 7.60	1688 mm (66.5")	1741 mm (68.5")	1511.0 mm (59.49")		

Note: Heaters with built-in thermostat come with tube extensions.

Table 16 – Performance Data for CF1 ProVector®

Model Number	kW (Btu/hr)	Unit Voltage	Basic Unit	Gas Group				Supply Wire Size ***	Unit Current Fuse*	Max. Circuit Fuse	Cabinet Length	Temperature Code
				IIB		IIC						
		w/o T'stat		w/ T'stat	w/o T'stat	w/ T'stat	AWG					
CF1-220150-010-T4	1.0 (3412)	220	✓	✓	✓	✓	✓	12	4.6	15	796 (31.3)	T4
CF1-220150-015-T3	1.5 (5118)	220		✓	✓	✓	✓	12	6.9	15	796 (31.3)	T3
CF1-220150-030-T2	3.0 (10236)	220		✓	✓	—	—	12	13.8	15	796 (31.3)	T2
CF1-220150-040-T3	4.0 (13648)	220		✓	✓	—	—	10	18.3	20	1256 (49.4)	T3
CF1-220150-064-T2**	6.4 (21837)	220		✓	—	—	—	8	29	30	1511 (59.5)	T2
CF1-230150-011-T4	1.1 (3753)	230		✓	✓	✓	✓	12	4.8	15	796 (31.3)	T4
CF1-230150-017-T3	1.7 (5801)	230		✓	✓	✓	✓	12	7.2	15	796 (31.3)	T3
CF1-230150-030-T3	3.0 (10236)	230		✓	✓	✓	✓	12	13	15	1256 (49.4)	T3
CF1-230150-033-T2	3.3 (11260)	230		✓	✓	—	—	10	14.4	15	796 (31.3)	T2
CF1-230150-044-T2	4.4 (15013)	230		✓	✓	—	—	10	19.2	20	1256 (49.4)	T2
CF1-230150-070-T2**	7.0 (23885)	230		✓	—	—	—	8	30.3	35	1511 (59.5)	T2
CF1-240150-012-T4	1.2 (4095)	240		✓	✓	✓	✓	12	5	15	796 (31.3)	T4
CF1-240150-018-T3	1.8 (6142)	240		✓	✓	✓	✓	12	7.5	15	796 (31.3)	T3
CF1-240150-030-T3	3.0 (10236)	240		✓	✓	✓	✓	12	12.5	15	1256 (49.4)	T3
CF1-240150-036-T2	3.6 (12284)	240		✓	✓	—	—	10	15	20	796 (31.3)	T2
CF1-240150-048-T2	4.8 (16378)	240		✓	✓	—	—	10	20	25	1256 (49.4)	T2
CF1-240150-076-T2**	7.6 (25932)	240		✓	—	—	—	8	31.7	35	1511 (59.5)	T2
CF1-254150-030-T3	3.0 (10236)	254		✓	✓	✓	✓	12	11.8	15	1256 (49.4)	T3
CF1-380150-0075-T4	0.75 (2559)	380		✓	✓	✓	✓	12	2	15	796 (31.3)	T4
CF1-380150-011-T4	1.1 (3753)	380		✓	✓	✓	✓	12	3	15	796 (31.3)	T4
CF1-380150-023-T3	2.3 (7848)	380		✓	✓	—	—	12	5.9	15	796 (31.3)	T3
CF1-380150-030-T3	3.0 (10236)	380		✓	✓	✓	✓	12	7.9	15	1256 (49.4)	T3
CF1-380150-036-T3	3.6 (12284)	380		—	—	✓	✓	12	9.4	15	1256 (49.4)	T3
CF1-380150-048-T2	4.8 (16378)	380		✓	✓	—	—	12	12.5	15	1511 (59.5)	T2
CF1-400150-0083-T4	0.83 (2832)	400		✓	✓	✓	✓	12	2.1	15	796 (31.3)	T4
CF1-400150-013-T4	1.3 (4436)	400		✓	✓	✓	✓	12	3.1	15	796 (31.3)	T4
CF1-400150-025-T3	2.5 (8530)	400		✓	✓	—	—	12	6.3	15	796 (31.3)	T3
CF1-400150-033-T3	3.3 (11260)	400		✓	✓	✓	✓	12	8.3	15	1256 (49.4)	T3
CF1-400150-036-T3	3.6 (12284)	400		—	—	✓	✓	12	9	15	1256 (49.4)	T3
CF1-400150-053-T2	5.3 (18084)	400		✓	✓	—	—	12	13.2	15	1511 (59.5)	T2
CF1-415150-009-T4	0.90 (3071)	415		✓	✓	✓	✓	12	2.2	15	796 (31.3)	T4
CF1-415150-014-T4	1.4 (4777)	415		✓	✓	✓	✓	12	3.2	15	796 (31.3)	T4
CF1-415150-027-T2	2.7 (9213)	415		✓	✓	—	—	12	6.5	15	796 (31.3)	T2
CF1-415150-036-T3	3.6 (12284)	415	✓	✓	✓	✓	12	8.7	15	1256 (49.4)	T3	
CF1-415150-057-T2	5.7 (19449)	415	✓	✓	—	—	12	13.7	15	1511 (59.5)	T2	

All units are single phase.

Units can be operated at 50 or 60 Hz.

* Or equivalent breaker as per local electrical inspection authority requirements.

** Optional thermostats not available as it exceeds current rated capacity.

*** Ensure supply wire size adheres to applicable local and national electrical codes.

Note:

1. Heater is functioning normally if, at rated voltage, the current draw is within 10% of the value in this table.
2. Operation at lower voltages that rated will result in reduced output and current draw. Actual Output (kW) = [(Supply Voltage)² ÷ (Rated Voltage)²] × Rated Unit Wattage (kW).
3. Add suffix "T" for optional built-in thermostat.
4. Add suffix "H" for high-temperature ambient storage option. High temperature storage option is not available with thermostat option. Not available on IIB models.
5. For IIB model with XCT built-in thermostat - Zones 1 & 2, Groups IIA and IIB.
6. For IIC model with XTWA built-in thermostat - Zones 1 & 2, Groups IIA, IIB, IIC.
7. IIC Grouping units come with x-Max® housing.
8. Remote mounted, Defender, explosion-proof room thermostats are not suitable for IIC applications.
9. Temperature code ratings: T2 - 300°C (572°F), T3 - 200°C (392°F), T4 - 135°C (275°F).

General Specifications

- Approvals 
- Hazardous Location Classifications

Without built-in thermostat:
Defender® housing; Zones 1 & 2, Groups IIA, IIB
x-Max® housing; Zones 1 & 2, Groups IIA, IIB, & IIC

With built-in thermostat:
XCT Defender® thermostat: Zones 1 & 2, Groups IIA & IIB
XT thermostat: Zones 1 & 2, Groups IIA, IIB, & IIC
- Enclosures
Cast or extruded aluminum supplied with either a bolt-on cover or two screwed-on covers. Suitable for either a Defender® or x-Max® thermostat.
- Mounting Brackets
Two 14-gauge (2 mm / 0.075") galvanized steel brackets for standard cabinet. Stainless-steel brackets provided with optional stainless-steel cabinet.
- Heating Elements
Two Incoloy® 840 sheathed elements.
- Temperature Code Rating
Temperature Code T2 - 300°C (572°F), T3 - 200°C (392°F) or T4 - 135°C (275°F)
- Temperature Limitations
Operational: -45°C to 40°C (-49°F to 104°F)
Storage: -45°C to 80°C (-49°F to 176°F).
Optional up to 149°C (300°F) available.
- Cabinet Material
14-gauge (2 mm / 0.075") epoxy coated steel with galvanized rear panel. Optional 14-gauge 304 stainless-steel cabinet and mounting hardware available

Table 17 – Cabinet Length, Net Weight, & Shipping Weight

		Nominal kW		
		0.75 to 3.00 (220 V) & 3.30 (T2), 3.60 (T2)	3.00 to 4.40 & 4.80 (240 V)	4.80 (380 V) to 7.60
Cabinet Length	in	31.3	49.4	59.5
	mm	796	1256	1511
Net Weight	lbs	58	86	96
	kg	27	39	43.6
Shipping Weight	lbs	65	95	105
	kg	30	44	48

Model Coding

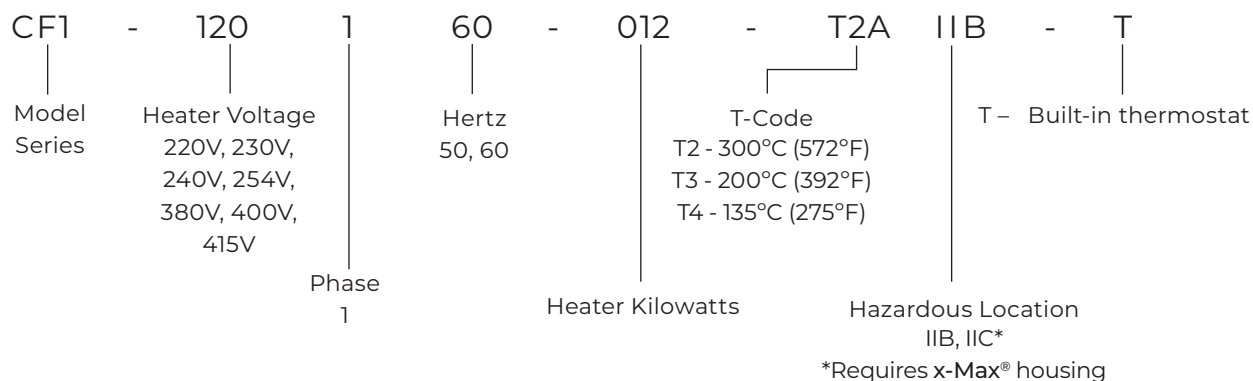

Note:

This nomenclature illustration is intended primarily to explain how a product part number is defined. Not all voltage and/or wattage combinations are available - please consult the catalogue chart(s) for product availability.